



ProGard™ Multigas Detector

Operating Manual

WARNING

THIS MANUAL MUST BE CAREFULLY READ BY ALL INDIVIDUALS WHO HAVE OR WILL HAVE THE RESPONSIBILITY FOR USING OR SERVICING THE PRODUCT. Like any piece of complex equipment, the ProGard Multigas Detector will perform as designed only if it is used and serviced in accordance with the manufacturer's instructions. OTHERWISE IT COULD FAIL TO PERFORM AS DESIGNED AND PERSONS WHO RELY ON THIS PRODUCT FOR THEIR SAFETY COULD SUSTAIN SEVERE PERSONAL INJURY OR DEATH.

The warranties made by Mine Safety Appliances Company with respect to the product are voided if the product is not used and serviced in accordance with the instructions in this manual. Please protect yourself and others by following them. We encourage our customers to write or call regarding this equipment prior to use or for any additional information relative to use or repairs.

CAUTION

For safety reasons, this equipment must be operated by qualified personnel only. Read and understand the instruction manual completely before operating.

In the U.S., to contact your nearest stocking location, dial toll-free 1-800-MSA-2222.
To contact MSA International, dial 1-412-967-3354 or 1-800-MSA-7777.

This manual pertains to instruments with Serial Number prefix "A".

© COPYRIGHT MINE SAFETY APPLIANCES COMPANY 1999 - All Rights Reserved

Table of Contents

Chapter 1	
Safety and General Limitations	1-1
Certifications	1-1
Electromagnetic Interference	1-1
▲ WARNING	1-2
GENERAL LIMITATIONS and ▲ WARNINGS	1-2
▲ CAUTIONS	1-4
Chapter 2	
Using the ProGard Multigas Detector	2-1
Preparation	2-1
Battery Pack Installation	2-1
Figure 2-1. Battery Pack Installation	2-1
Figure 2-2. Self Test	2-2
Figure 2-3. Select Display Language	2-2
Figure 2-4. Time and Date Set	2-3
Figure 2-5. Power OFF	2-3
Figure 2-6. Time Set	2-3
Figure 2-7. Time Set Complete	2-4
Figure 2-8. Day, Month, Year	2-4
Figure 2-9. Date Set Complete	2-4
Turning ON the ProGard Multigas Detector	2-5
Figure 2-10. Power OFF	2-5
Figure 2-11. Measure: Power ON	2-5
Figure 2-12. Show Alarms	2-6
Figure 2-13. Alarm Setpoints, Low Oxygen Alarm	2-6
Figure 2-14. Alarm Setpoints, High Oxygen Alarm	2-6
Fresh Air Set Up Option	2-7
▲ WARNING	2-7
Figure 2-15. Measure: Please wait	2-7
Figure 2-16. Fresh Air Set-up	2-7
To Proceed With Fresh Air Setup:	2-8
To Bypass The Fresh Air Set Up:	2-8
Using the ProGard Multigas Detector	2-9
Exposure Display	2-9
Figure 2-17. Exposure Page	2-9
Battery Condition	2-10

Table of Contents

Figure 2-18. Battery Condition	2-10
▲ WARNING	2-11
▲ WARNING	2-11
Time Display	2-11
Figure 2-19. Time Display	2-11
Calibration Check	2-12
▲ CAUTION	2-12
Measuring Gas Concentrations	2-12
Combustible Gases (COMB)	2-12
▲ WARNING	2-13
▲ CAUTION #1	2-13
Figure 2-20. Combustible Gas Alarm Flag	2-13
▲ CAUTION #2	2-14
Oxygen Measurements	2-14
▲ WARNING	2-14
Toxic Gas Measurement	2-14
Figure 2-21. Oxygen Alarm Flag	2-14
▲ WARNING	2-15
Peak Reading Page	2-15
Optional Displays	2-15
Peak Readings	2-15
Figure 2-22. Peak Readings	2-15
Figure 2-23. Reset Peak Readings	2-15
Optional Sampling Equipment	2-16
Pump Module Option	2-16
▲ CAUTION	2-16
Removing the Pump Module	2-16
Using Sampling Equipment:	2-16
Figure 2-24. Pump Installation	2-16
Attaching Probe to Sampling Line	2-17
Figure 2-25. Attaching Probe to Sample Line	2-17
Figure 2-26. Changing the Probe Filter	2-17
Changing the Probe Filter	2-18
Turn ON Instrument and Verify Proper Operation	2-18
▲ WARNING	2-18
▲ CAUTION	2-18
Removing Sampling Equipment	2-18

Table of Contents

Turning OFF the ProGard Detector	2-19
Battery Pack Removal	2-19
Recharging Nickel-Cadmium (Ni-Cd) Battery Packs	2-19
Figure 2-27. Power Down	2-19
Figure 2-28. Ni-Cd Charger (120V version shown)	2-20
Chapter 3,	
Calibration	3-1
▲ CAUTION	3-1
Calibration Adjustment	3-1
Preparing to Calibrate	3-1
▲ WARNING	3-1
Calibration Procedures	3-2
Figure 3-1. Calibration Cap or Pump Module Installation	3-2
Figure 3-2. Calibration - No/Yes?	3-2
Figure 3-3. Apply Fresh Air	3-3
Figure 3-4. Adjusting Zeroes	3-3
Figure 3-5. Combustible Gas Calibration Display	3-3
Figure 3-6. Combustible Gas Span Adjustment.....	3-4
Oxygen Sensor Calibration	3-5
CO Sensor Calibration	3-5
Figure 3-7. Oxygen Reading Verification.....	3-5
Figure 3-8. Apply CO Gas	3-5
H ₂ S Sensor Calibration	3-6
Figure 3-9. Adjust CO Gas Calibration	3-6
Figure 3-10. Calibration Update	3-6
Figure 3-11. Remove Cal Cap	3-7
Figure 3-12. Please Wait	3-7
Figure 3-13. Power OFF.....	3-7
Chapter 4	
General Maintenance and Troubleshooting	4-1
▲ WARNING	4-1
Cleaning and Routine Care	4-1
Figure 4-1. Sensor Cover Plate	4-1
▲ CAUTION	4-2
Storage	4-2
▲ WARNING	4-2
Shipment	4-2

Table of Contents

Troubleshooting	4-3
Table 4-1. Troubleshooting Guidelines	4-3
Repair Procedures	4-4
Battery Pack Replacement	4-4
Remove the Battery Pack	4-4
Figure 4-2. Battery Pack Removal	4-4
Replace the Battery Pack	4-5
Sensor Replacement	4-5
Figure 4-3. Sensor Replacement.....	4-5
Main Electronics Board Replacement	4-6
▲ CAUTION	4-6
Figure 4-4. Chassis and Sensor Removal	4-6
Figure 4-5. Mounting Screw Location	4-7
Figure 4-6. Power Connector Removal.....	4-7
Display Module Replacement	4-8
Figure 4-7. Display-to-Chassis Mounting Screws	4-9
Sensor Board Replacement	4-10
Chapter 5	
Performance Specifications	5-1
Performance Specifications	5-1
Relative Responses to Combustible Gases	5-2
Interference Gases Cross Sensitivity	5-3
Carbon Monoxide Sensors	5-3
Hydrogen Sulfide Sensors	5-3
Chapter 6	
Parts List	6-1
Table 6-1. Parts List	6-1

Chapter 1

Safety and General Limitations

Certifications

Tests completed by MSA verify that the ProGard Multigas Detector meets applicable industry and government standards (as of date of manufacture), including those for Electromagnetic Interference.

Electromagnetic Interference

This equipment has been type tested and found to comply with the limits for a Class A digital device, pursuant to Part 15 of the FCC Rules. These limits are designed to provide reasonable protection against harmful interference when the equipment is operated in a commercial environment. This equipment generates, uses, and can radiate radio frequency energy and, if not installed and used in accordance with the instruction manual, may cause harmful interference to radio communications. Operation of this equipment in a residential area is likely to cause harmful interference in which case the user will be required to correct the interference at his own expense.

This equipment was tested and found to comply with the limits for a Class B digital device, pursuant to Part 15 of the FCC Rules. These limits are designed to provide reasonable protection against harmful interference in a residential installation.

This equipment generates, uses, and can radiate radio frequency energy and, if not installed and used in accordance with the instructions, may cause harmful interference to radio communications. However, there is no guarantee that interference will not occur in a particular installation. If this equipment does cause harmful interference to radio or television reception, which can be determined by turning the equipment OFF and ON, the user is encouraged to try to correct the interference by one or more of the following measures:

- Reorient or relocate the receiving antenna.
- Increase the separation between the equipment and receiver.
- Connect the equipment into an outlet on a circuit different from that to which the receiver is connected.
- Consult the dealer or an experienced radio TV technician for help.

This digital apparatus does not exceed the Class A limits for radio noise emissions from digital apparatus set out in the Radio Interference Regulations of the CRTC.

⚠ WARNING

Changes or modifications to this unit not expressly approved by the party responsible for compliance could void the user's authority to operate the equipment.

GENERAL LIMITATIONS and ⚠ WARNINGS

The ProGard Detector detects gases and vapors in air only. It cannot measure combustible or toxic gases in:

- reducing atmospheres
- furnace stacks
- environments with inert gas backgrounds

Do not use the ProGard Detector to measure combustible or toxic gases when the amount of oxygen is:

- deficient
- enriched

The ProGard Detector measures combustible gases and vapors. It cannot measure the presence of combustible:

- airborne mists such as lubricating oils
- airborne dusts such as grain or coal dust

The ProGard Detector contains sensors which detect specific toxic gases. The instrument must be used to detect only those specific gases. Other toxic hazards may be present; the ProGard Detector is not intended to detect these other hazards.

Certain materials such as:

- silicone
- silicates
- lead-containing compounds such as leaded gasoline

tend to desensitize the combustible gas sensor, thereby giving erroneously low readings. Calibration checks must be made frequently if such materials are suspected to be present in the tested atmosphere.

If you do not recalibrate, the instrument may give false readings and endanger life and health.

For best accuracy, calibrate at the pressure of intended use. Readings will be inaccurate if the ProGard Detector is used to take samples that are at:

- low atmospheric pressure (below calibration pressure)
- high atmospheric pressure (above calibration pressure)

Combustible gases will burn or explode only when the fuel/air mixture is within certain proportions. The minimum concentration of a particular combustible gas in air which can be ignited is defined as the Lower Explosive Limit (LEL). In some references, the term Lower Flammability Limit (LFL) is used.

Combustible gas readings with an OVER alarm in the display indicate an amount of gas which may be above the Lower Explosive Limit (LEL) or above 5% methane (CH₄) by volume. Such readings are beyond the accurate range of the sensor. (See Chapter 4 for limits.)

When sampling with accessory sampling lines, use the shortest possible length to minimize the time needed to obtain a valid reading.

When sampling over liquids, the end of the sampling line must not touch the surface of the liquid. Otherwise, liquids may enter the instrument, causing internal damage. In addition, sample gas may be blocked from entering the line, and a false reading may occur.

Obstruction of the sensor holes in the instrument case causes erroneous readings. These holes must be kept open at all times. Do not use compressed air to clean the sensor holes; excessive pressure at the face of the sensors could damage them.

Do not use MSA Lead Inhibitor Filters with this instrument. Loss of sensitivity may result.

Battery packs must be recharged in a non-hazardous location free of combustible gases and vapors.

Dispose of used batteries in accordance with local health and safety regulations.

A calibration check should be included as part of a routine inspection of this instrument to ensure it is operating properly and readings are accurate. See the Passport Portable Alarm Technical Manual for calibration procedure details and calibration kit part numbers.

Use only genuine MSA replacement parts when performing any maintenance procedures described in this manual. Substitution of components may seriously impair instrument performance, alter intrinsic safety characteristics, or void agency approvals.

Repair or alteration of the ProGard Detector beyond procedures described in this manual could cause the instrument to fail to perform properly.

⚠ CAUTIONS

Acid gases, such as carbon dioxide, will shorten the service life of the oxygen sensor.

Do not push on the center of the oxygen or the toxic gas sensor. Be especially careful when installing or replacing a sensor. Damage to the sensor may result.

This instrument is designed for use only with the battery chargers listed in this manual. Use of other battery chargers may result in damage to the battery pack and instrument.

Before each day's use, perform a calibration check (see Chapter 2, "Calibration Check") and check the pump (if used) for proper operation. (See Chapter 2, "Pump Module Operation.")

Chapter 2 Using the ProGard Multigas Detector

It is your responsibility to know how to use the ProGard Multigas Detector. When used properly, the ProGard Detector will alert you to the presence of combustible gases and vapors and to atmospheres that are rich or deficient in oxygen. It will also alert you to the presence of Carbon Monoxide and/or Hydrogen Sulfide if equipped with the sensors for those gases.

Alarm levels are factory-set and meet the most commonly accepted standards; see "Turning ON the ProGard Multigas Detector" later in this chapter for more details.

Preparation

Battery Pack Installation

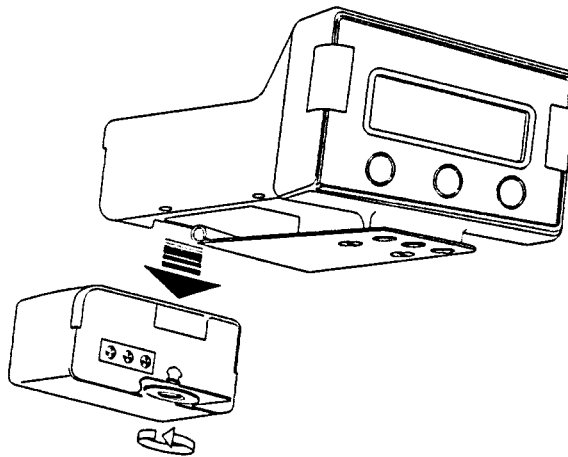

Figure 2-1.
Battery Pack Installation

1. Slide the battery pack toward the sensor face of the instrument, and turn the "quarter-turn fastener" on the bottom of the instrument in a clockwise direction.

2. The instrument responds:

- backlight flashes
- screen flashes
- alarm sounds
- alarm lights flash
- major electronic components are tested automatically.

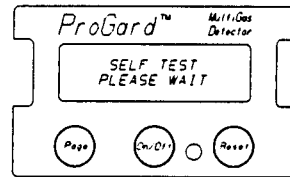

Figure 2-2.
Self Test

After tests are completed, either ERROR or OK appears on the display screen.

When **ERROR** appears:

- Alarm sounds.
(see Chapter 4, TABLE 4-1 Troubleshooting Guidelines.)

When **OK** appears:

- The following display appears:

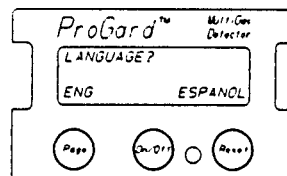

Figure 2-3.
Select Display Language

- Press **PAGE** (ENGL) to use English Displays.
- Press **RESET** (ESP) to use Spanish Displays.
- The instrument momentarily displays the Software version number.

The display now reads:

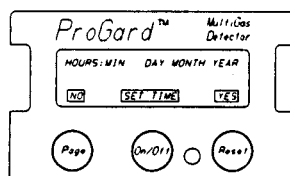

Figure 2-4.
Time and Date Set

To cancel the Time and date set, press the **PAGE (NO)** button or wait five seconds.

A long beep sounds and the display reads:

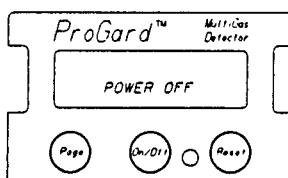

Figure 2-5.
Power OFF

To set the time, press the **RESET (YES)** button.

- The display now reads:

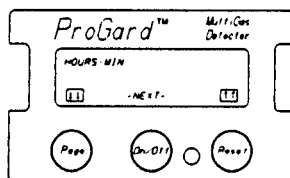

Figure 2-6.
Time Set

- The hour flashes:
 - Press the **PAGE** button to lower the hours.
 - Press **RESET** to raise the hours.
 - Press the **ON/OFF** button to accept the new number.
- The minutes now flash:
 - Adjust as needed.
 - Press the **ON/OFF (NEXT)** button to accept the reading.
- The display now reads:

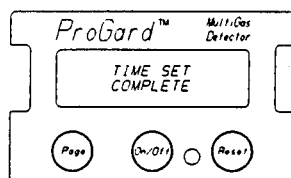

Figure 2-7.
Time Set Complete

- The display automatically displays:

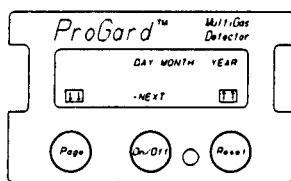

Figure 2-8.
Day, Month, Year

- The day flashes:
 - Press the **PAGE** button to lower the day.
 - Press **RESET** to raise the day.
 - Press **ON/OFF (NEXT)** to accept the reading.
- The month now flashes:
 - Adjust as needed.
 - Press **ON/OFF (NEXT)** to accept the reading.
- The year now flashes:
 - Adjust as needed.
 - Press **ON/OFF (NEXT)** to accept the reading.
- When the selected time/date values are set, the display reads:

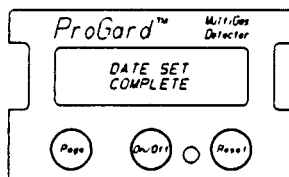

Figure 2-9.
Date Set Complete

- The Alarm sounds.

NOTE: The small battery on the main board which runs the clock has an estimated life of five to 10 years if the main battery pack is not installed, or is installed but completely discharged. This clock battery has a much longer life if a charged battery pack is installed on the ProGard Multigas Detector. If the clock is not holding the correct time when the battery pack is reinstalled, the clock battery is dead. Either replace the main board or send the ProGard Multigas Detector to a service center to have a new battery soldered onto the main board.

- **POWER OFF** displays for a few seconds, and the instrument turns OFF.

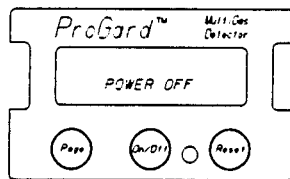

Figure 2-10.
Power OFF

- The ProGard Detector is ready for use after a calibration or response check is performed.

Turning ON the ProGard Multigas Detector

Push the ON/OFF button:

- The display flashes and reads:

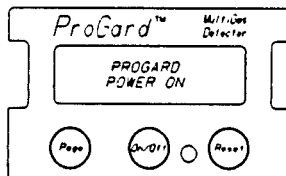

Figure 2-11.
Measure: Power ON

- The display backlight turns ON.
- The alarm lights flash.
- The alarm sounds and stops.

Chapter 2, Using the ProGard Multigas Detector

- The display reads:

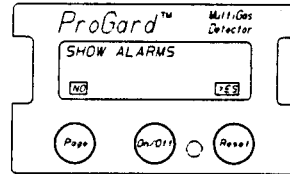

Figure 2-12.
Show Alarms

- Press **PAGE** (NO) to skip viewing the alarm setpoints.
- Press **RESET** (YES) to view the alarms.
 - Default after five seconds is to display alarm setpoints.
 - The following screens appear:

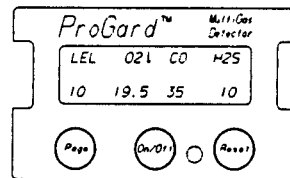

Figure 2-13.
Alarm Setpoints, Low Oxygen Alarm

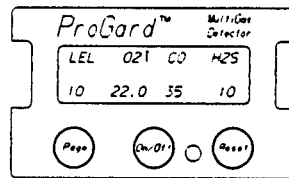

Figure 2-14.
Alarm Setpoints, High Oxygen Alarm

- The display flashes the four alarm setpoints with the low alarm for Oxygen.
- The display then flashes the high alarm setpoint for Oxygen.
- The instrument then checks its internal electronics and displays:

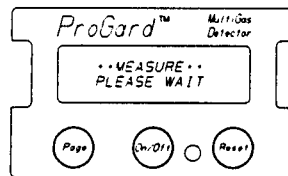

Figure 2-15.
Measure: Please wait

- After the ProGard Detector checks its internal electronics, it displays the Fresh Air Setup query.

Fresh Air Set Up Option

(for automatic zero adjustment of the ProGard Detector sensors)

The Fresh Air Setup (FAS) feature automatically zeroes the combustible and toxic channels. In addition, it calibrates the oxygen sensor to 20.8% (normal ambient oxygen concentration).

NOTE: The Fresh Air setup has limits. If a dangerous level of gas is present, the ProGard Detector ignores the FAS command and goes into alarm.

⚠ WARNING

Do not activate the fresh air setup unless you are certain you are in fresh, uncontaminated air; otherwise, inaccurate readings may occur. These inaccurate readings may falsely indicate that a hazardous atmosphere is safe, and injury or death could occur. If you have any doubts as to the quality of the surrounding air, do not use the fresh air setup feature.

Do not use the Fresh Air Setup as a substitute for regular calibration checks.

Persons responsible for the use of the ProGard Detector must determine whether or not the Fresh Air Setup option should be used. The user's abilities, training, and normal work practices must be considered when making this decision.

When the display reads:

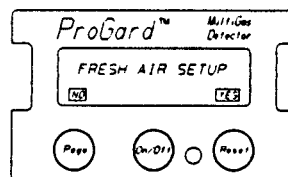

Figure 2-16.
Fresh Air Set-up

- The ProGard Detector is ready for its Fresh Air Set Up.

To Proceed With Fresh Air Setup:

1. Press the **RESET (YES)** button; the display reads:

**FRESH AIR SET UP
PLEASE WAIT**

- a. When the display reads:

**FRESH AIR SET UP
ERROR - CANCELED**

- Alarm sounds
- Lights flash.

- 1) Push the **RESET** button.
- 2) Make certain the ProGard Multigas Detector is in fresh air; move to another location, if necessary. Allow the ProGard Detector to warm up for a few minutes to allow the sensors to stabilize.

Turn ProGard Detector OFF and then back ON again.

- 3) If the ProGard Detector cancels the Fresh air Setup request again, calibration adjustments may be required. Report to the person responsible for ProGard Detector maintenance. Do not use the instrument for protection.

- b. When the Fresh Air Setup is completed:

- Instrument enters the Exposure display page and displays gas readings.
- Instrument is ready for use.

To Bypass The Fresh Air Set Up:

Press the **PAGE (NO)** button, or wait five seconds.

- Display enters Exposure page.
- Display begins to show gas readings.
- The instrument is ready for use.

If the sensors drift off of zero a few minutes after being turned ON, allow the ProGard Detector to warm up for 15 minutes, then try the Fresh Air Setup again.

Using the ProGard Multigas Detector

The ProGard Detector has four standard display pages. You can move sequentially from one to the next by pressing the **PAGE** button. You can return to the standard Exposure display page by waiting for 15 seconds or by pressing the **ON/OFF** button from another page.

The standard display pages are:

- Exposure display (normal)
- Battery condition
- Time and date
- Peak readings.

NOTE: The ProGard Multigas Detector measures concentrations of gases no matter what display page is shown. When an alarm condition is reached, the alarm sounds automatically. The measurements made by the Passport Alarm are NOT dependent upon a specific display page being shown.

Exposure Display

In this normal display page, numbers appear below the gas labels on the instrument's display:

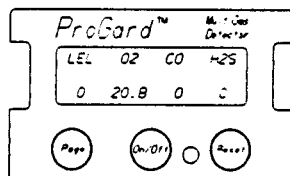

Figure 2-17.
Exposure Page

To change from the Exposure display to the Battery Condition page, press the **PAGE** button.

Battery Condition

The display reads:

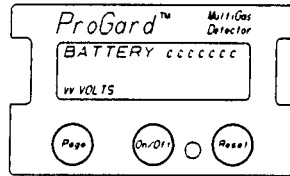

Figure 2-18.
Battery Condition

- **v.v** is the voltage from the battery
- **cccc** is one of three battery conditions that can be displayed on the Battery display page:
 - **OK:** enough voltage to function properly
 - **LOW:**
 - **BATT** appears in the Exposure Display Page
 - Horn sounds (Press the **RESET** button to silence it.)
 - After initial **LOW** warning, the horn sounds approximately every five minutes
 - The battery will operate the ProGard Detector for approximately 10 more minutes provided the **RESET** button is pressed after each warning.
 - The instrument will continue to operate until the power is turned OFF or the battery condition is at **BATTERY SHUTDOWN** level.
 - **BATTERY SHUTDOWN:** the battery is no longer able to operate the instrument, and:
 - **BATTERY SHUTDOWN** appears in place of the Exposure Display Page. Horn sounds continuously and cannot be reset.
 - Alarm lights flash.
 - No other pages can be viewed.
 - After approximately five minutes, the instrument shuts down automatically.

⚠ WARNING

When the Battery Shutdown condition sounds, stop using the instrument. It cannot alert you of potential hazards because it does not have enough power to operate properly. You must:

1. Leave the area immediately.
2. Turn OFF the instrument if it is ON.
3. Report to the person responsible for maintenance. Replace or recharge the battery pack.

If you do not follow this procedure, you could be injured or killed.

⚠ WARNING

Do not use rechargeable nickel cadmium batteries in Alkaline battery packs. The Alkaline battery warning and alarm setpoints are not optimized for nickel cadmium batteries. The low battery warning and alarm could occur too quickly to be noticed. If you do use nickel cadmium batteries in the alkaline battery pack you could be injured or killed.

NOTE: The Passport unit recognizes the type of battery pack (rechargeable nickel cadmium or replaceable alkaline) is attached and automatically adjusts the low battery warning and alarm setpoints.

Time Display

Press the PAGE button

In the third standard display page, the time and date are displayed. The time is displayed in a 24-hour format. For example, "Sept. 1 1992" would read as follows at 3 p.m.:

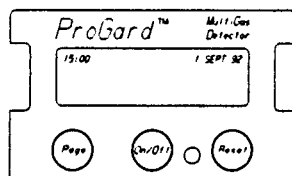

Figure 2-19.
Time Display

Calibration Check

CAUTION

The following calibration check should be performed before each day's use. This calibration check is very simple and should only take one to five minutes, depending on the number and type of gases your ProGard Detector is equipped to sense. Turn the ProGard Detector ON in clean fresh air, and verify that the readings indicate no gas present. If necessary, perform the procedure given in "Fresh Air Setup Option" earlier in this Chapter.

1. Attach the pump module or calibration cap to the ProGard Detector, orienting the inlet fitting to point toward the battery pack.
2. Attach the calibration adapter (P/N 636246) to the calibration cap or pump module.
3. Attach regulator (supplied in calibration kit) to the cylinder.
4. Connect the black tubing (supplied in calibration kit) to the regulator.
5. Open the valve on the regulator, and connect the other end of the tubing to the inlet fitting.

The flow rate of the regulator is 0.25 lpm. Note the readings on the Passport display; they should be within the limits stated on the calibration cylinder or limits determined by your company. (If necessary, change cylinders to introduce other calibration gases.)

If the readings are not within these limits, the ProGard Detector requires recalibration. Return the instrument to your maintenance facility, or refer to Chapter 3, "Calibration" for detailed calibration instructions.

Measuring Gas Concentrations

Combustible Gases (COMB)

The ProGard Detector detects combustible gases in the atmosphere. The Alarms sound when concentrations reach:

- Alarm setpoint, or
- 100% LEL (Lower Explosive Limit).

When the combustible gas indication reaches the Alarm Setpoint:

- Alarm sounds

- Alarm lights flash;

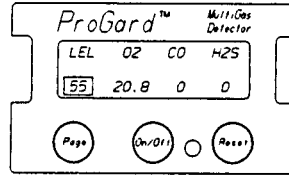

Figure 2-20.
Combustible Gas Alarm Flag

- Press the **RESET** button to silence the alarm.
- Concentration of gas flashes in the display.

When the combustible gas indication reaches 100% LEL of the combustible gas:

- Alarm sounds;
- This alarm *cannot* be reset with the **RESET** button.

The LockAlarm™ circuit locks the combustible gas reading and alarm if the gas reading exceeds 100% LEL.

- **OVER** appears on the display.

The alarm can only be reset by turning off the instrument and moving to a safe, fresh-air environment.

⚠ WARNING

When the **OVER** alarm condition is reached, you are in a life-threatening situation; there is enough gas in the atmosphere for an explosion to occur.

You must:

1. Leave the area immediately.
2. Turn **OFF** the instrument and do not turn it **ON** again until the instrument is in fresh air.

If you do not follow this procedure, you could be seriously injured or killed.

⚠ CAUTION #1

Any Rapid up-scale reading followed by a declining or erratic reading may indicate a gas concentration beyond upper-scale limit, which may be hazardous.

⚠ CAUTION #2

High off-scale readings (indicated by "OVER") may indicate an explosive concentration. Only the combustible gas detection portion of this instrument has been assessed for performance.

Oxygen Measurements

The ProGard Detector detects the amount of oxygen in the atmosphere. There are two conditions which trigger the alarm:

- Too little oxygen (deficient)
- Too much oxygen (enriched)

At the Alarm Setpoint for either:

- Alarm sounds
- Alarm light flashes
- Concentration of gas flashes in the display:

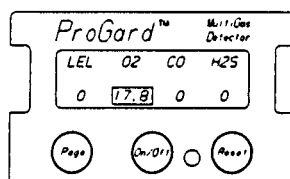

Figure 2-21.
Oxygen Alarm Flag

⚠ WARNING

When the OXYGEN alarm sounds, you may be in a life-threatening situation. You must follow your company's work and safety procedures; otherwise, you could be seriously injured or killed.

Toxic Gas Measurement

The ProGard Detector can be ordered to detect Carbon Monoxide and/or Hydrogen Sulfide gases in the atmosphere. Each of these sensors has a setpoint which causes an alarm if the gas level goes above that setpoint. When this happens:

- Alarm sounds
- Alarm lights flash
- Concentration of gas flashes in the display.

⚠ WARNING

When the TOXIC GAS alarm sounds, you may be in a life-threatening situation. You must follow your company's work and safety procedures; otherwise, you could be seriously injured or killed.

Peak Reading Page

Optional Displays

Press the **PAGE** button twice to move to:

Peak Readings

This shows the highest levels of gas that the ProGard Detector recorded since it was turned ON or since the peak readings were reset. Both the high and low oxygen readings are displayed.

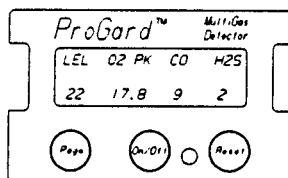

Figure 2-22.
Peak Readings

To reset the Peak Readings back to zero:

1. In Peak display, press the **RESET** button.

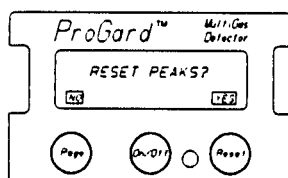

Figure 2-23.
Reset Peak Readings

2. Press the **RESET (YES)** button to reset peak readings or press the **PAGE (NO)** button or wait 15 seconds to cancel.

Press the **PAGE** button to move to return to the Exposure Page.

Optional Sampling Equipment

Sampling lines and related equipment permit samples of gas to be taken from remote or inaccessible locations.

Sampling lines are 5 to 50 feet long and are made of a synthetic material specifically compounded to resist absorption of combustible and toxic vapors. Gases are drawn through the lines to the ProGard Detector by a pump.

Using the shortest possible line reduces the time the pump must run before valid samples and readings can be obtained.

Pump Module Option

When ordered, the pump module is packed separately and may be installed before using the ProGard Detector:

1. Position the pump module as shown, the inlet must point toward the battery.
2. Hand-tighten the screws until snug.

⚠ CAUTION

Do not over-tighten the screws.

Removing the Pump Module

1. Loosen screws.
2. Remove pump module.

Using Sampling Equipment:

1. Turn OFF the ProGard Detector.
2. Install the Pump Module if it is not already attached (FIGURE 2-24).

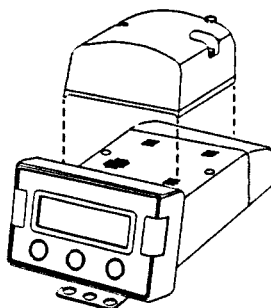

Figure 2-24. Pump Installation

NOTE: Do not over-tighten the thumb screws on the pump module in an effort to eliminate a leak. The thumb screws should be finger-tight only.

3. Attach the Sampling Hose to the Pump Module as shown. See FIGURES 2-25 and 2-26.

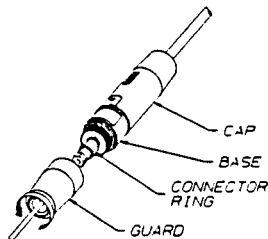

Figure 2-25. Attaching Probe to Sample Line

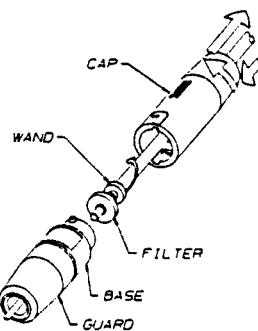

Figure 2-26. Changing the Probe Filter

Attaching Probe to Sampling Line (FIGURE 2-25)

1. Grasp the probe handle by the top two sections [the large section (cap) with the MSA logo and the center section (base) with the label].
2. Unscrew lower section (guard) from the label section.
3. Feed male end of the sample line through the guard and screw into the exposed connector ring on the probe.
4. Screw the guard back onto the base.

Changing the Probe Filter

1. Grasp the probe handle by the base and guard.
2. Push the cap section toward the other two and turn clockwise (the spring will push the sections apart).
3. Grasp and spin the wand clockwise while pulling to disengage.
4. Remove the water trap filter and replace.
5. Re-assemble the probe handle.

Turn ON Instrument and Verify Proper Operation

1. Plug the free end of the sampling line or probe. The pump motor shuts down and an alarm sounds. (The readings on the display may change.)

When the pump inlet/sample line/probe is blocked, the pump alarm must activate. If the alarm does not activate, check the pump/sample line/probe for leaks; once the leak is fixed, recheck the pump alarm by blocking the flow. Check the pump before each day's use.

⚠ WARNING

Do not use the pump/sample line/probe unless the pump alarm activates when the flow is blocked. Lack of an alarm is an indication that a sample may not be drawn to the sensors, which could cause inaccurate readings. Failure to follow the above can result in serious personal injury or death.

Periodically, while checking the pump, it will try to restart. It cannot restart until the sampling line is opened. When the line is open the pump restarts automatically.

2. Press the RESET button to reset the alarm.

⚠ CAUTION

Never let the end of the sampling line touch or go under any liquid surface. If liquid is sucked into the instrument, readings will be inaccurate and the instrument could be damaged. We recommend the use of an MSA Sample Probe (part no. 497600, 800332, 800333, or equivalent) containing a special membrane filter, permeable to gas but impermeable to water, to prevent such an occurrence.

Removing Sampling Equipment

1. Turn OFF the ProGard Detector.
2. Unscrew the connector ring on the sampling line, and remove the sampling line.

Turning OFF the ProGard Detector

Push and hold **ON/OFF** button for five seconds; a countdown appears:

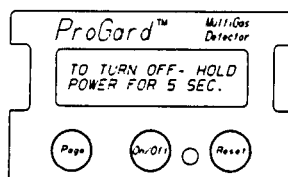

Figure 2-27.
Power Down

Battery Pack Removal

1. Turn the power OFF by pressing and holding the **ON/OFF** button for five seconds.
 - **POWER OFF** appears on the display.
2. Turn the "quarter-turn fastener" on the back of the instrument in a counterclockwise direction.
3. Slide the battery pack away from the sensor face.

Recharging Nickel-Cadmium (Ni-Cd) Battery Packs

The Passport Ni-Cd rechargeable battery packs are charged using the MSA Omega® battery charging system only. Look for the Omega symbol Ω on the battery pack and charger to make sure they are compatible. Use of any other charger may damage or improperly charge the batteries.

The battery pack will be fully recharged after 16 hours. The Passport unit should be turned off or the battery pack should be removed from the Passport unit during charging. Be certain that the charger is properly connected by checking to see that the charger's LED is lit.

No matter how long the Passport unit was run (one hour or a full shift), the battery pack can be left on charge indefinitely without causing damage - providing that the battery pack was recharged at room temperature. The MSA Omega charger will recharge, but not over-charge, the battery pack.

The battery pack may be charged when it is connected to the ProGard Detector or when it is removed. If the battery pack is connected to the ProGard Detector:

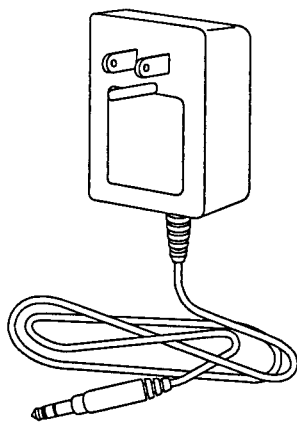

Figure 2-28.
Ni-Cd Charger (120V version shown)

1. Turn OFF the instrument.
2. Insert the charger plug into the jack on the battery pack.
3. Plug the charger into a matching receptacle.

The red light on the charger lights if the charger is properly connected.

BATTERY TYPE	PROGARD OPERATING TIME (without derating/at 20°C)	
	WITHOUT PUMP	WITH PUMP
A. NiCd Standard	10-12 hours	8-10 hours
B. 'C' Alkaline	18-20 hours	16 hours

Chapter 3, Calibration

⚠ CAUTION

Before each days usage, sensitivity must be tested on a known concentration of calibration gas equivalent to 25 to 60% of full scale concentration. Accuracy must be within -0 to +20% of actual. Accuracy may be corrected by specific adjustment procedure.

Calibration Adjustment

ProGard Detector calibration can be adjusted easily by using gases of known mixtures and concentrations. Check the calibration each day before using your ProGard Detector.

The user can calibrate the gas sensors in the following order:

- Combustible Gas
- Oxygen
- Carbon Monoxide (if equipped)
- Hydrogen Sulfide (if equipped).

Preparing to Calibrate

Before starting, be certain that the instrument is in normal fresh air, free of combustible or toxic gases. To prepare to calibrate:

1. Turn OFF the ProGard Detector.
2. Allow the instrument to stabilize for several minutes in fresh air at the temperature and air pressure of intended use.

⚠ WARNING

The ProGard Multigas Detector does not provide any protection while the calibration is being adjusted. To enable the alarm function, the internal switches must be set for normal operation and the instrument must be turned ON.

Calibration Procedures

1. Install the pump module (if used) as shown (if using the calibration cap, do not install it until later):

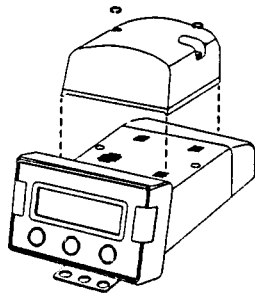

Figure 3-1.
Calibration Cap or Pump Module Installation

2. Push and hold the **PAGE** and **RESET** buttons. While continuing to hold these two buttons, press the **ON/OFF** button.
 - The instrument turns ON in the Calibration mode.
 - The display is:

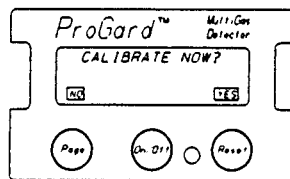

Figure 3-2.
Calibration - No/Yes?

- If the instrument turns ON in the Normal mode, turn it OFF and try again, making sure all three buttons are held down simultaneously.

To Cancel Calibration:

Press the **PAGE (NO)** button or wait five seconds.

- The ProGard Detector begins warming up and enters the Exposure display page.

To Continue Calibration:

3. Press the **RESET (YES)** button.
 - Display prompts you for Fresh Air.

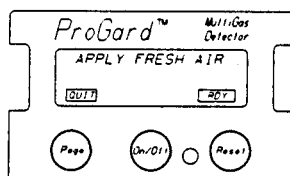

Figure 3-3.
Apply Fresh Air

NOTE: At this point, allow the instrument to warm up for approximately one minute

To cancel:

Press the **PAGE (QUIT)** button.

- Instrument beeps and automatically shuts OFF.

To proceed:

4. Press the **RESET (READY)** button.
5. Wait approximately 15 seconds for the ProGard Detector to complete the fresh air adjustments.
 - During this time, the display appears:

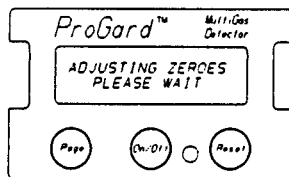

Figure 3-4.
Adjusting Zeroes

After the fresh air adjustments are made, the ProGard Detector is ready to begin gas calibration.

- The combustible gas Calibration page appears:

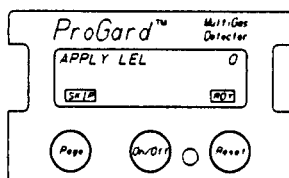

Figure 3-5.
Combustible Gas Calibration Display

Now attach the calibration cap if pump module is not being used.

Press the **PAGE (SKIP)** button to skip calibration for any gases you do *not* want to change.

6. Attach the Gas Cylinder.
 - Attach a 0.25 lpm (liters-per-minute) Flow Controller to the gas cylinder.
 - Attach the short piece of calibration tubing (provided) to the ProGard Detector Pump Module inlet.
 - Attach the other end of the Sample Line to the 0.25 lpm Flow Controller.
 - The ProGard Detector Pump stops and does not restart until the gas tank nozzle is opened or an end of the sample line is opened.
 - Turn the knob on the gas regulator in a counterclockwise direction.
 - The ProGard Detector Pump Module automatically restarts.
7. Press the **RESET (READY)** button (see FIGURE 3-5).
8. Wait for the readings to stabilize.

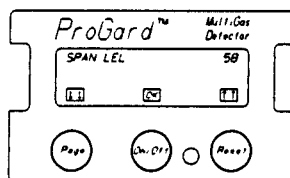

Figure 3-6.
Combustible Gas Span Adjustment

NOTE: During calibration, the display reading may appear more unstable than normal. The display's digital filtering has been disabled to provide the most rapid reading possible.

9. After the display stabilizes, adjust the display reading to agree with the known concentration of calibration gas.
 - a. Push the **PAGE (DOWN)** button to lower the reading (FIGURE 3-6).
 - b. Push the **RESET (UP)** button to raise the reading.
 - Holding either button causes the reading to change more quickly.

10. Push the **ON/OFF** (OK) button to accept the reading.
 - The new reading is stored in memory, and the ProGard Detector automatically moves to the Oxygen reading.
11. Change the gas cylinder, if needed:

Oxygen Sensor Calibration

After the combustible calibration is completed, the ProGard Detector moves automatically to the Oxygen calibration.

- The Oxygen sensor reading is automatically adjusted to 20.8 during the zeroing sequence.
- During this part of the calibration sequence, simply observe the Oxygen reading to verify it is within the limits indicated on the cylinder.

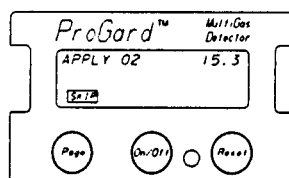

Figure 3-7.
Oxygen Reading Verification

Press **PAGE** (SKIP) to continue on to the toxic gas calibrations.

CO Sensor Calibration

(if equipped; otherwise, skip to "H₂S Sensor Calibration.")

The ProGard Detector moves to the CO calibration.

- Ensure that CO gas is applied to the instrument.
- Press **RESET** (READY) to reset the CO gas reading.

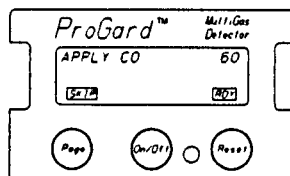

Figure 3-8.
Apply CO Gas

Chapter 3, Calibration

- Allow gas reading to stabilize.
- Adjust the reading to agree with the known concentration of CO in the cylinder.

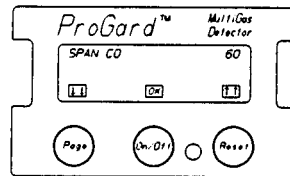

Figure 3-9.
Adjust CO Gas Calibration

- Press the **ON/OFF (OK)** button to accept the reading.
 - The instrument proceeds to H₂S calibration, if equipped.

H₂S Sensor Calibration

- Ensure that H₂S gas is applied to the instrument.
- Press **RESET (READY)** to reset the H₂S gas reading.
- Allow gas reading to stabilize.
- Adjust the reading to agree with the known concentration of H₂S in the cylinder.
- Press the **ON/OFF (OK)** button to accept the reading.

After the final gas is calibrated, the instrument sounds a long beep and the following display appears:

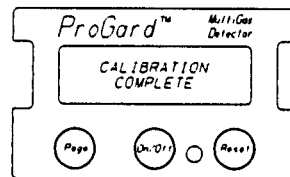

Figure 3-10.
Calibration Update

- The following display then appears:

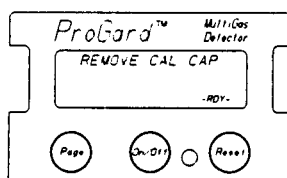

Figure 3-11.
Remove Cal Cap

- Remove the calibration cap or the calibration gas from the pump module. Press the **RESET (READY)** button.

NOTE: Be sure to turn **OFF** the gas cylinder regulator and remove it from the cylinder to prevent gas from leaking out when not in use.

The Display now reads:

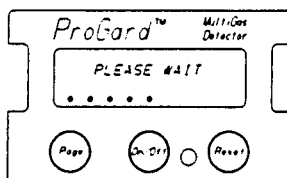

Figure 3-12.
Please Wait

and allows the calibration gases to clear from the sensors (about 30 seconds).

A long beep sounds and the ProGard Detector turns OFF automatically:

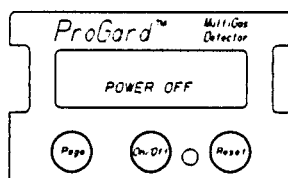

Figure 3-13.
Power OFF

Chapter 4 General Maintenance and Troubleshooting

As with all electronic equipment, the ProGard Detector will operate only if it is cared for and maintained properly.

⚠ WARNING

Repair or alteration of the ProGard Detector beyond the scope of these instructions by anyone other than a person authorized by MSA may void all warranties and approvals. Such repairs may also endanger persons who rely on this equipment for their safety or health. When needed, use only genuine MSA replacement parts.

Cleaning and Routine Care

The case of the ProGard Detector should be cleaned periodically with a soft cloth dampened with water. If any sensor holes on the front of the instrument are blocked with dirt, they must be cleaned:

1. Remove the sensor cover plate.
2. Clean the holes in the plate with a paper clip, wire, or similar

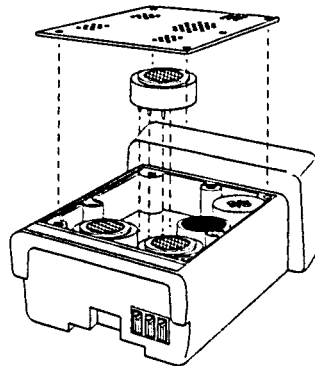

Figure 4-1.
Sensor Cover Plate

device. The holes may also be cleaned with oil-free compressed air.

⚠ CAUTION

Do not attempt to clean the sensor cover plate while it is in place; otherwise, the sensors may be damaged. The tops of sensors are very fragile. Do not touch or apply pressure to the tops of any sensors. If a sensor is damaged it may cause the instrument to give false readings.

The sensor cover plate contains holes for five sensors. In instruments with *less* than five sensors, some of these holes are permanently blocked with special sealing membranes. Do not puncture these membranes, or erroneous gas readings may result.

Storage

Store your ProGard Detector in a safe, dry place when it is not in use. Be sure that the storage area temperature is between 23 and 104 degrees Fahrenheit (-5 and 40 degrees Celsius).

- When the ProGard Detector is stored for more than one month, rechargeable battery packs should be periodically charged to prevent battery damage.
- When the ProGard Detector is stored for less than 20 days, recharge the rechargeable battery pack or replace alkaline batteries before storing.
- To store these models for more than 20 days, attach the unit to a battery charger and charge with the proper MSA charger or periodically replace alkaline batteries with fresh cells.

⚠ WARNING

After storage, always recheck the calibration of the instrument before use. During storage, sensors may drift or become inoperative and may not provide warnings of danger to the health and lives of users.

Shipment

1. Remove the battery pack before shipment. When the ProGard Detector is returned for repairs, disconnect the normally used battery pack from the unit, and include it in the container.
2. Pack the ProGard Detector in its original shipping container with suitable padding. If the original container is

unavailable, ask your MSA representative for a replacement. An equivalent container may be substituted if necessary. In either case, seal the instrument in a plastic bag to protect it from moisture. Protect the ProGard Detector from the rigors of handling with sufficient padding. Damage due to improper packaging or damage in shipment is not covered by the instrument's warranty.

Troubleshooting

The ProGard Multigas Detector will operate reliably for years when cared for and maintained properly. If the instrument becomes inoperative, follow the Troubleshooting Guidelines in TABLE 4-1. These represent the most likely causes of a problem.

Table 4-1. Troubleshooting Guidelines				
PROBLEM	REPLACE			
	BATTERY PACK*	DISPLAY MODULE	SENSOR	MAIN ELECTRONICS MODULE
Does not turn ON	√			√
Does not complete Self-Tests				√
Display segments missing or stuck		√		
ERROR message after battery installation				√
ERROR message during use				√
Battery pack does not hold charge	√			
Combustible sensor does not calibrate			√	
Oxygen sensor does not calibrate			√	
Toxic sensor does not calibrate			√	
Clock not holding time.				√
* Recharge or replace the cells before replacing battery pack.				
In all of the above cases and for any other problems, you may return the ProGard Multigas Detector to MSA for repairs.				

You may return inoperative instruments to MSA for repair.

**MSA Instrument Division
Service Department
Walden Road
Mars, PA 16046
1-800-MSA-INST**

To contact MSA International, please call:

1-412-967-3000 or 1-800-MSA-7777

When an inoperative component is located by using the guidelines, it may be replaced by using one of the following procedures:

Repair Procedures

Battery Pack Replacement

Remove the Battery Pack

1. Turn the "quarter-turn fastener" on the back of the instrument in a counterclockwise direction.

NOTE: Do not remove any other screws from the Ni-Cd battery pack.

2. Slide the battery pack away from the sensor face.

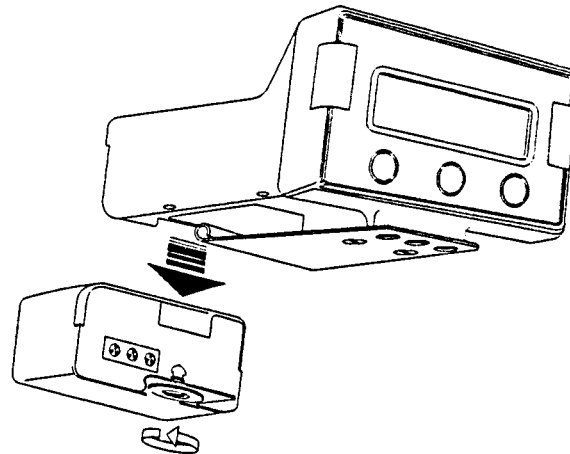

**Figure 4-2.
Battery Pack Removal**

Replace the Battery Pack

3. Examine the sliding battery contacts for damage.
4. Slide the battery pack toward the sensor face.
5. Turn the "quarter-turn fastener" on the back of the instrument in a clockwise direction.

Sensor Replacement

1. Turn OFF the power, and remove the battery pack.
2. Remove the Pump Module or Calibration Cap, if installed.
3. Remove the sensor cover plate.
4. Unplug, remove, and properly dispose of the desired sensor.
5. If the replacement sensor is equipped with a shorting plate, clip or wire attached to its pins, remove it before inserting the replacement sensor.
6. Replace the sensor gasket
7. Align the sensor cover plate with the sensors, and be certain that it completely covers the sensors.
8. Recalibrate the instrument before using.

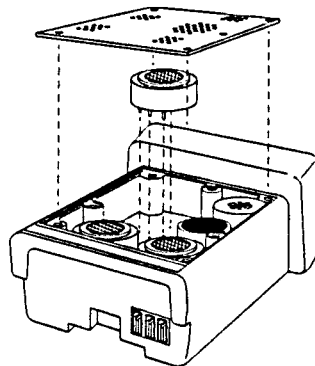

Figure 4-3.
Sensor Replacement

Main Electronics Board Replacement

CAUTION

Before handling the PC boards, ensure you are properly grounded; otherwise, static charges from your body could damage the electronics. Such damage is not covered by the warranty. Grounding straps and kits are available from electronics suppliers such as Radio Shack.

1. Turn the power OFF, and remove the battery pack.
2. Remove the Pump Module or Calibration Cap, if installed.
3. Remove the sensor cover screws.
4. Remove the sensor cover plate.
5. Remove the "hold-down" screws.
6. Remove the sensors.
7. Slide the chassis out halfway.
8. Disconnect the ear-phone connector.
9. Completely slide out the chassis.
10. Remove the four main electronics board mounting screws.

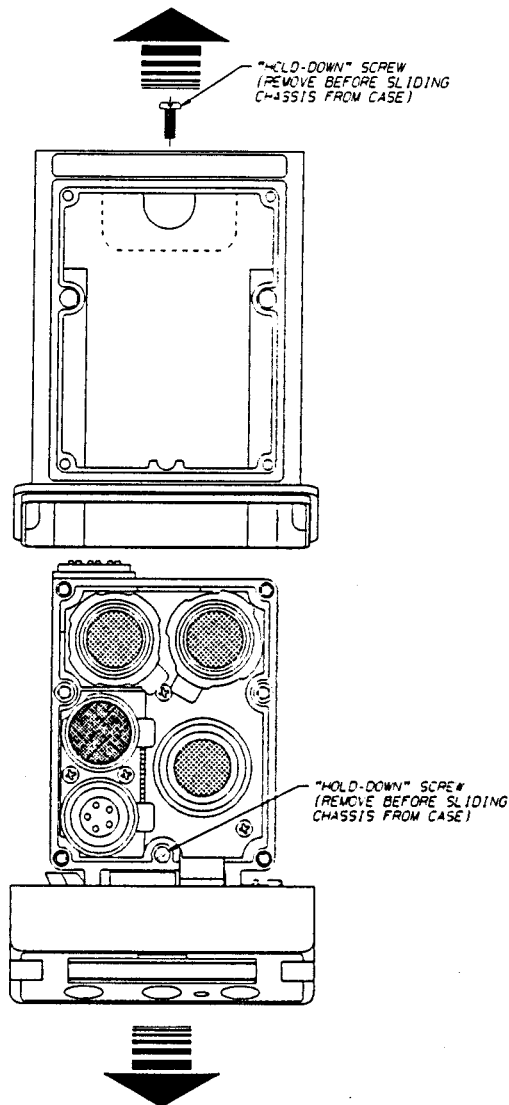

Figure 4-4.
Chassis and Sensor Removal

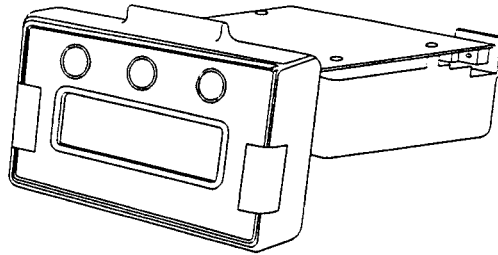

Figure 4-5.
Mounting Screw Location

11. Turn the instrument over, and lift up the main board to a 45-degree angle; disconnect the power connector.

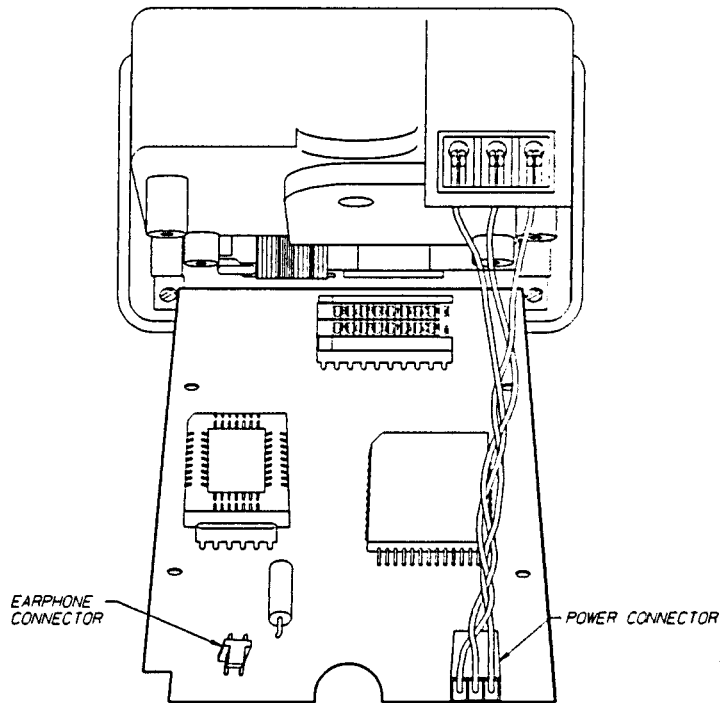

Figure 4-6.
Power Connector Removal

Chapter 4, General Maintenance and Troubleshooting

12. Lift up the board to about 90 degrees, and remove:
 - display connector
 - sensor connector
 - keypad connector
13. Remove the board.
14. Set the switches on the new main electronics board to the same positions as those set on the old Main Electronics Board.
15. Insert the new main electronics board.
16. Connect the
 - keypad connector
 - display connector
 - sensor connectorto the new board.
17. Connect the power connector.
18. Fasten the four module-board mounting screws.
19. Slide the chassis half-way into the case.
20. Connect the ear-phone connector.
21. Slide the chassis completely into the case.
22. Install the "hold-down" screws.
23. Install the sensor cover plate, aligning the holes over the sensors.
24. Completely recalibrate the ProGard Detector.
25. Verify the alarm setpoints; adjust them if necessary.

Display Module Replacement

1. Turn the power off, and remove the battery pack.
2. Remove the Pump Module or the Calibration Cap, if installed.
3. Remove the sensor cover screws.
4. Remove the sensor cover plate.
5. Remove the "hold-down" screws.
6. Slide the chassis out halfway.
7. Disconnect the ear-phone connector.
8. Completely slide out the chassis

9. Turn the instrument over, and remove the four mounting screws.
10. Lift up the main electronics board to a 45-degree angle, and disconnect the power connector (FIGURE 4-6).
11. Lift up the main electronics board to about 90 degrees. Remove:
 - display connector
 - sensor connector
 - keypad connector
12. Remove the two screws holding the display to the chassis.
 - a. Remove the four screws holding the display module to the face piece.

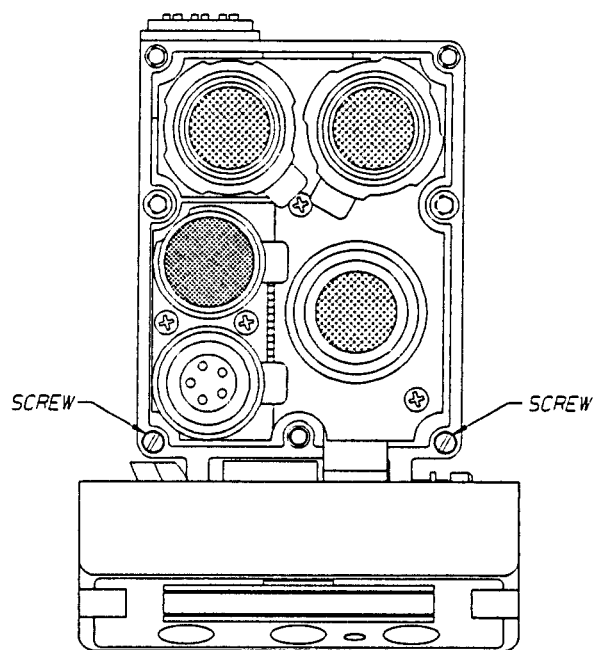

Figure 4-7.
Display-to-Chassis Mounting Screws

13. Remove the display module.
14. Install the new display module.
15. Fasten the display mounting screws.
16. Connect the
 - keypad connector
 - display connector
 - sensor connectorto the main electronics module.
17. Connect the power connector.
18. Replace the four module mounting screws.
19. Slide the chassis half-way into the case.
20. Connect the ear-phone connector.
21. Slide the chassis completely into the case.
22. Replace the "hold-down" screws.
23. Replace the sensor cover plate, aligning the holes over the sensors.
24. Complete recalibration of the ProGard Detector is recommended as a performance check.

Sensor Board Replacement

1. Turn the power OFF, and remove the battery pack.
2. Remove the Pump Module or Calibration Cap, if installed.
3. Remove the sensor cover screws.
4. Remove the sensor cover plate.
5. Remove the "hold-down" screws.
6. Slide the chassis out halfway.
7. Disconnect the ear-phone connector.
8. Completely slide out the main electronics board
9. Remove the four main electronics-board mounting screws.
10. Turn the instrument over, and lift up the main board to a 45-degree angle; disconnect the power connector.
11. Lift up the board to about 90 degrees, and remove:
 - display connector
 - sensor connector
 - keypad connector

12. Remove the board.
13. Remove all sensors.
14. Remove the four mounting screws.
15. Remove the Sensor Board from the chassis, and replace it with a new Sensor Board, reinstalling the screws and sensors, from 13 and 14 above.
16. Connect the:
 - keypad connector
 - display connector
 - sensor connectorto the main electronics module.
17. Connect the power connector.
18. Replace the four module mounting screws.
19. Slide the chassis half-way into the case.
20. Connect the ear-phone connector.
21. Slide the chassis completely into the case.
22. Replace the "hold-down" screws.
23. Replace the sensor cover plate, aligning the holes over the sensors.
24. Calibrate the ProGard Multigas Detector.

Chapter 5

Performance Specifications

Performance Specifications		
COMBUSTIBLE GAS	Range	0 to 100% LEL or
		0 to 5% CH ₄
	Resolution	1% LEL or
		0.1% CH ₄
	Reproducibility	3% LEL to 50% LEL reading
5% LEL to full scale or		
0.2% CH ₄ to 2.5% Methane		
Response Time	0.3% CH ₄ to full scale	
OXYGEN	Range	90% of final reading in 30 seconds (normal temperature range)
	Range	0 to 25% O ₂
	Resolution	0.1% O ₂
	Reproducibility	0.3% O ₂ , for 2 to 25% O ₂
Response Time	90% of final reading	30 seconds (normal temperature range)
		3 minutes (extended temperature range)
CARBON MONOXIDE (APPROPRIATE MODELS ONLY)	Range	1000 ppm CO
	Resolution	1 ppm CO
	Reproducibility	±2 ppm CO or
		10% of reading, whichever is greater
Response Time	90% of final reading in 40 seconds (normal temperature range)	
HYDROGEN SULFIDE (APPROPRIATE MODELS ONLY)	Range	50 ppm H ₂ S
	Resolution	1 ppm H ₂ S
	Reproducibility	±2 ppm H ₂ S or
		10% of reading, whichever is greater
Response Time	90% of final reading in 65 seconds (normal temperature range)	
TEMPERATURE RANGE	Normal	0 to 40° C
	Extended	-10 to 40° C

Relative Responses to Combustible Gases

The following relative responses to selected combustible gases are typical of an instrument calibrated using Pentane.

COMBUSTIBLE GAS	MULTIPLY %LEL READING BY	COMBUSTIBLE GAS	MULTIPLY %LEL READING BY
Acetone	1.1	Methylcyclohexane	1.1
Acetylene	0.7	Methyl Ethyl Ketone	1.1
Acrylonitrile ¹	0.8	Methyl Tertiary Butyl Ether	1.0
Benzene	1.1	Mineral Spirits	1.1
Butane	1.0	iso-Octane	1.1
1,3 Butadiene	0.9	n-Pentane	1.0
n-Butanol	1.8	Propane	0.8
Carbon Disulfide ¹	2.2	Propylene	0.8
Cyclohexane	1.1	Styrene ²	1.9
2,2 Dimethylbutane	1.2	Tetrahydrofuran	0.9
2,3 Dimethylpentane	1.2	Toluene	1.1
Ethane	0.7	Vinyl Acetate	0.9
Ethyl Acetate	1.2	VM&P Naptha	1.6
Ethyl Alcohol	0.8	O-Xylene	1.2
Ethylene	0.7	Response Notes: 1. The compounds may reduce the sensitivity of the combustible gas sensor by poisoning or inhibiting the catalytic action. 2. These compounds may reduce the sensitivity of the combustible gas sensor by polymerizing on the catalytic surface. 3. For an instrument calibrated on Pentane, multiply the displayed %LEL value by the conversion factor above to get the true %LEL. 4. These conversion factors should be used only if the combustible gas is known. 5. These conversion factors are typical for a Passport Portable Alarm. Individual units may vary by $\pm 25\%$ from these values.	
Formaldehyde ²	0.5		
Gasoline (unleaded)	1.3		
Heptane	1.1		
Hydrogen	0.6		
n-Hexane	1.3		
Isobutane	0.9		
Isobutyl Acetate	1.5		
Isopropyl Alcohol	1.1		
Methane	0.5		
Methanol	0.6		
Methyl Isobutyl ketone	1.1		

Interference Gases Cross Sensitivity

SAMPLE	PASSPORT RESPONSE
Carbon Monoxide Sensors	
1000 ppm Toluene/Air	1
0.58% Benzene/Air	1
1.6% Acetone/Air	2
100 ppm Isobutylene/Air	1
0.8% Hydrogen/Air	1000
0.75% Pentane/Air	1
3.9% CO ₂ /N ₂	1
7.5 ppm Chlorine/Air	0
50 ppm HCl/Air	0
10 ppm HCN/Air	0
50 ppm NO/Air	12
5 ppm NO ₂ /air	0
10 ppm SO ₂ /Air	-2
These responses are typical over the entire -10°C to 40°C temperature range.	
Hydrogen Sulfide Sensors	
1000 ppm Toluene/Air	0
0.58% Benzene/Air	0
1.6% Acetone/Air	0
100 ppm Isobutylene/Air	0
0.8% Hydrogen/Air	-4
0.75% Pentane/Air	0
3.9% CO ₂ /N ₂	0
1.49% Ethanol/Air	2
7.5 ppm Chlorine/Air	0
50 ppm HCl/Air	0
10 ppm HCN/Air	0
50 ppm NO/Air	-1
5 ppm NO ₂ /Air	0
10 ppm SO ₂ /Air	1
These responses are typical over the entire -10°C to 40°C temperature range.	
NOTES: These conversion factors are typical for a ProGard Multigas Detector. Individual units may vary by ±25% from these values.	

Chapter 6 Parts List

PART	PART NO.
Pump Module	497430
Calibration Cap	497367
Battery Pack, Standard Ni-Cd Rechargeable	496990
Probe - 1 ft.	800332
Probe - 3 ft.	800333
Sampling Line - 5 ft.	497332
Sampling Line - 10 ft.	497333
Sampling Line - 15 ft.	497334
Sampling Line - 25 ft.	497335
Replacement Filter, Probe	801582
Charger, Omega 120 VAC	494716
Charger, Omega 220 VAC	495965
Charger, Omega 110/220 VAC, Five Unit	801759
Charger, Omega 12 volt	800525
Calibration Kit Model RP with 0.25 lpm Regulator	477149
Calibration Gas - LEL pentane simulant / 15% O ₂ ; 60 ppm CO	478191
Calibration Gas - LEL pentane simulant / 15% O ₂ ; 300 ppm CO and 10 ppm H ₂ S	804770
Calibration Gas - LEL pentane simulant / 15% O ₂ ; 10 ppm H ₂ S	804769
Quick-connect Calibration Adapter	636246
Main Electronics Board	813112
Display Module	804029
Sensor Board	806397
Combustible Gas Sensor	478537
O ₂ Sensor	480566
CO Sensor	636240
H ₂ S Sensor	636241